

McVeigh Parker

XFENCE Security Systems

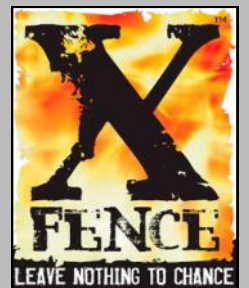



The advantage of a simple system, designed to effectively secure the roads and highways used by dense traffic and railways (TGV), the golf courses, parks and green areas.

It is an excellent fencing solution consisting of a post with wire support and an anchor post and offering speed and ease of strong installation with the following salient features :

- No drillings,
- No concrete,
- Easy installation due to its wire supports,
- Less deterioration of the ground,
- Fixing the mesh on the borders of the allotted land,
- Possibility of installation at less than 0°C.

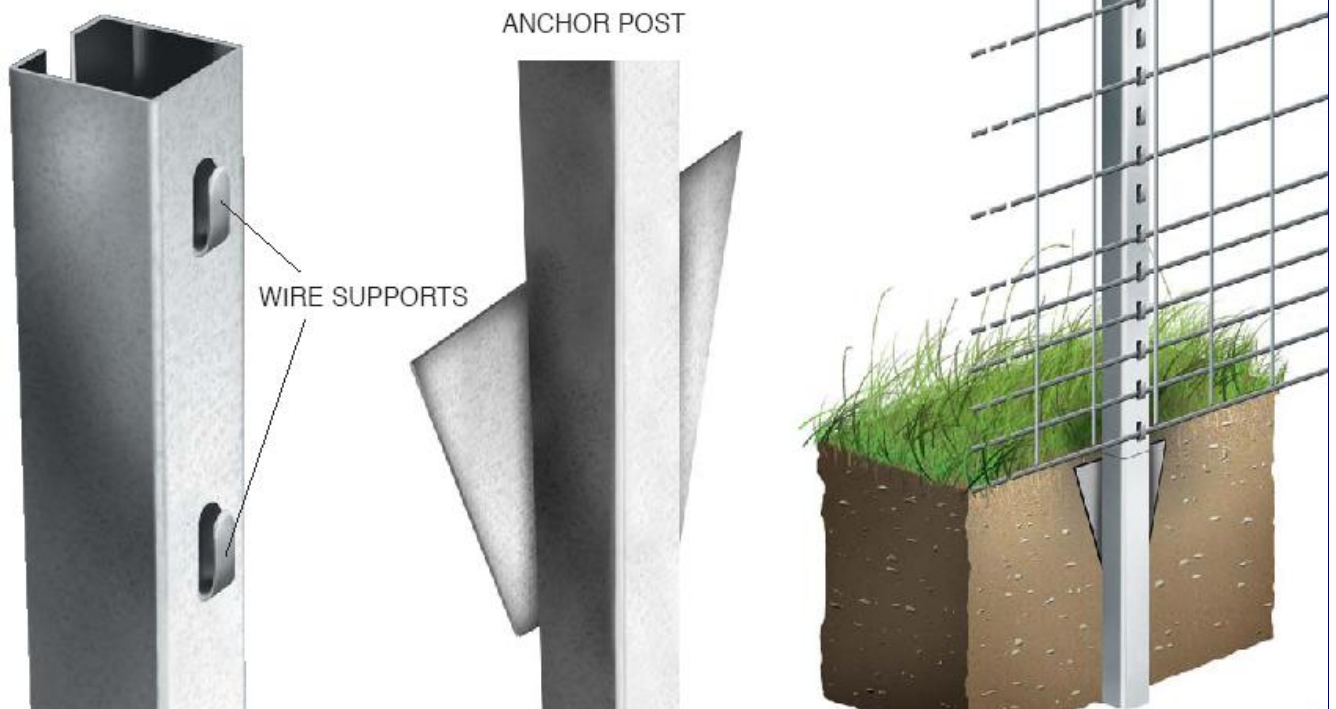

simple and cost effective



an innovating system.

There are various fencing systems for long linear fences; what distinguishes XFENCE Security Systems is its simplicity of installation, speed of implementation, safety, performance in time, and its saving in final financial outlay.

The great originality of the XSS posts resides in the fact that it is complete and sufficient in itself not involving any concrete or earth-works. The time saving is considerable.

The system is installed with very little equipment, a simple pneumatic drill suffices. The simplicity and ease of transportation to site make this a very easy fence to install in the most inaccessible places.



Its principle is based on the prior laying of perfectly stable and resistant anchor post with base plate, on which the support post are fitted together.

Other important advantages of XSS system

The posts can be fixed after tensioning the mesh, thus facilitating installation within the boundaries of the allotted land or easy reinstatement of the anti-rabbit netting towards the interior. This fixing of the posts after tensioning of the mesh is easier as there is no waiting period for concrete to set because the system requires no concrete.

The fixing of the mesh to the post is ultra fast due to the system of wire supports.

Once installed, your XFENCE System gives you the assurance and stability of a system that will perform for life.

Green powder coating
(Ral 6005) version available



Only stocked in standard lengths and specific fixation points, other specifications can be manufactured if suitable quantities are required.

PRODUCTION EXAMPLE

SMALL LINEAR FENCES
Fences < 2000 ml

 = **300m/day**

- 1 vehicle
- 1 compressor
- 3 men

LONG LINEAR FENCES
Fences ≥ 2000 ml

 + **Distribution**

- 1 vehicle
- 1 man

 + **Fixing of the anchor posts**

- 1 tractor with pneumatic drill
- 2 men

 + **Fixing of posts and props**

- 2 men

 + **Fixing of mesh**

1 Team comprising :

- 1 unrolling tractor
- 3 men

=

More than 1500m/day

IN NORMAL INSTALLATION CONDITIONS EXCLUDING FOR EXAMPLE VERY UNEVEN RELIEFS, NATURE OF THE GROUND (HARD ROCK)



An easy implementation in 5 stages :

1. Positioning of the alignment wire/cord , then the anchor posts



2. Fixing of anchor posts



3. Fixing of posts



4. Fixing of mesh/
Positioning and
tensioning



5. Closing the wire
supports





CONFIGURATION

INTERMEDIARY POST

CAUTION

Take care to loop the post on the anchor post as common sense dictates

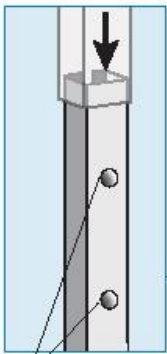

Double anti-disjointing notched on the front face of the anchor posts

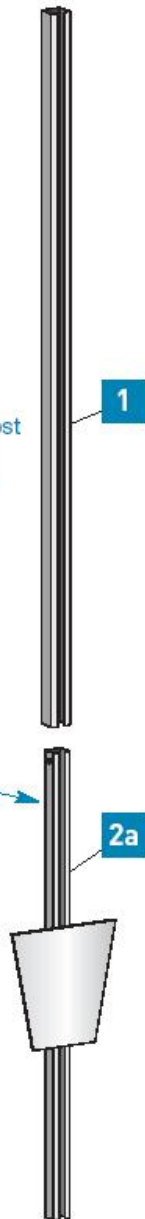

Post with angled heighteners

Post with straight heightener

1	POST (pitch of 101.6)
2a	STRAIGHT ANCHOR POST
10	ANGLED HEIGHTENERS
11	STRAIGHT HEIGHTENER



CONFIGURATION

TERMINAL POST WITH PROPS ON ANCHOR POST

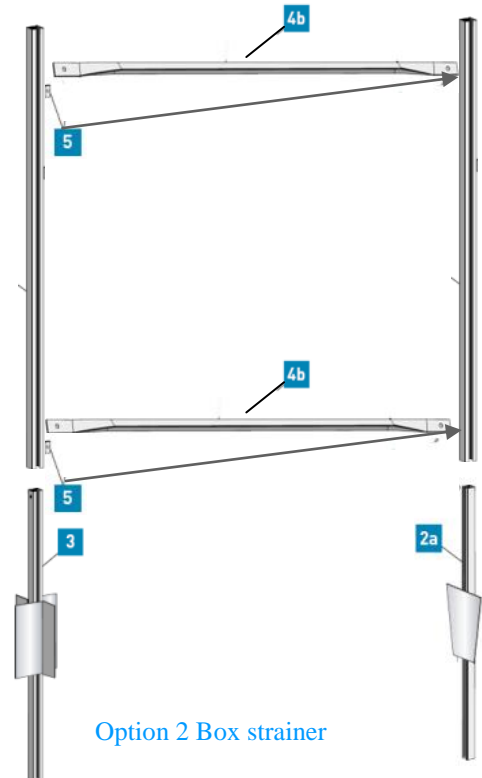
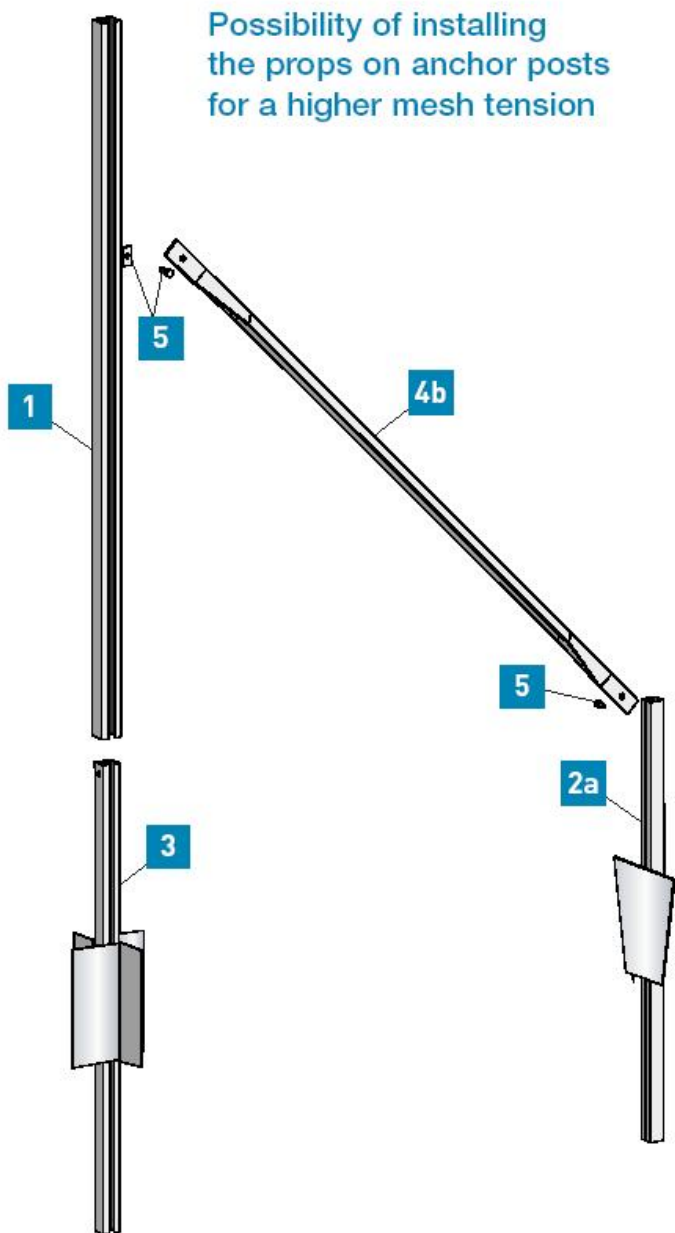

1	POST (pitch of 101.6)	5	HAMMERING PLATE - SCREW TH 10X30
2a	STRAIGHT ANCHOR POST		
3	CORNER ANCHOR POST		
4b	PROPS ON ANCHOR POST		



CONFIGURATION

TENSIONING POST WITH PROPS ON ANCHOR POST

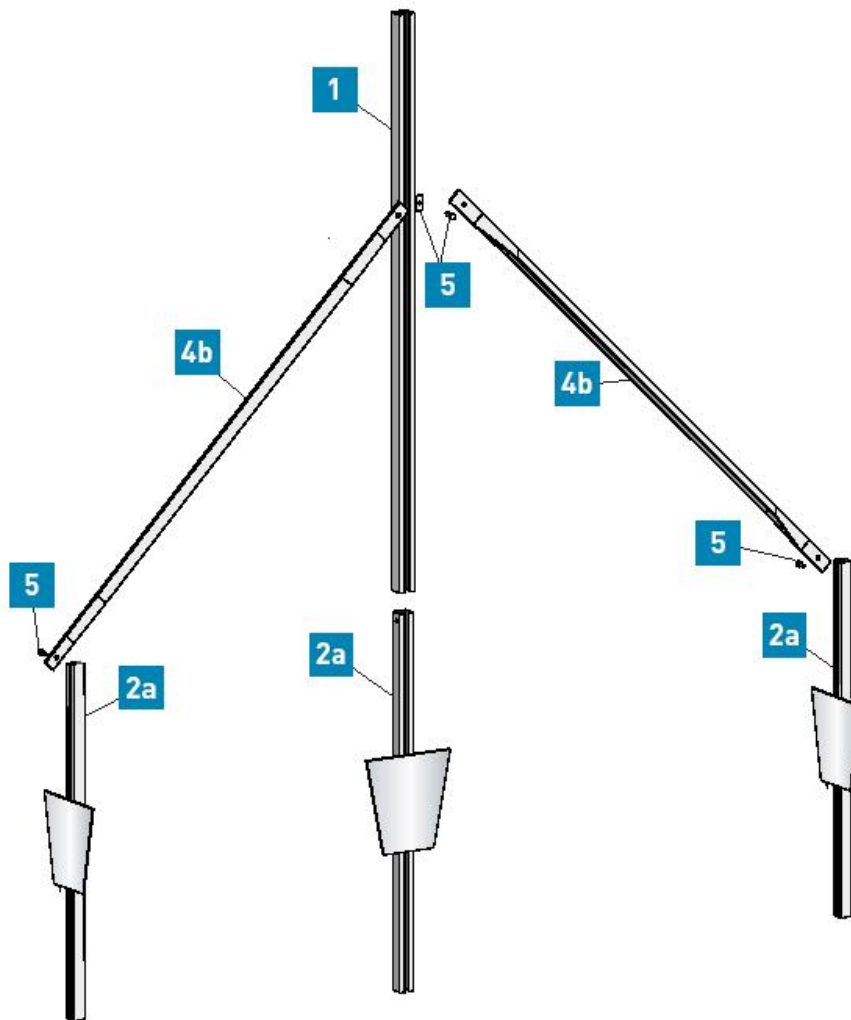

1	POST (pitch of 101.6)
2a	STRAIGHT ANCHOR POST
4b	PROPS ON ANCHOR POST
5	HAMMERING PLATE + SCREW TH 10X30



CONFIGURATION

TENSIONING POST WITH PROPS ON ANCHOR POST

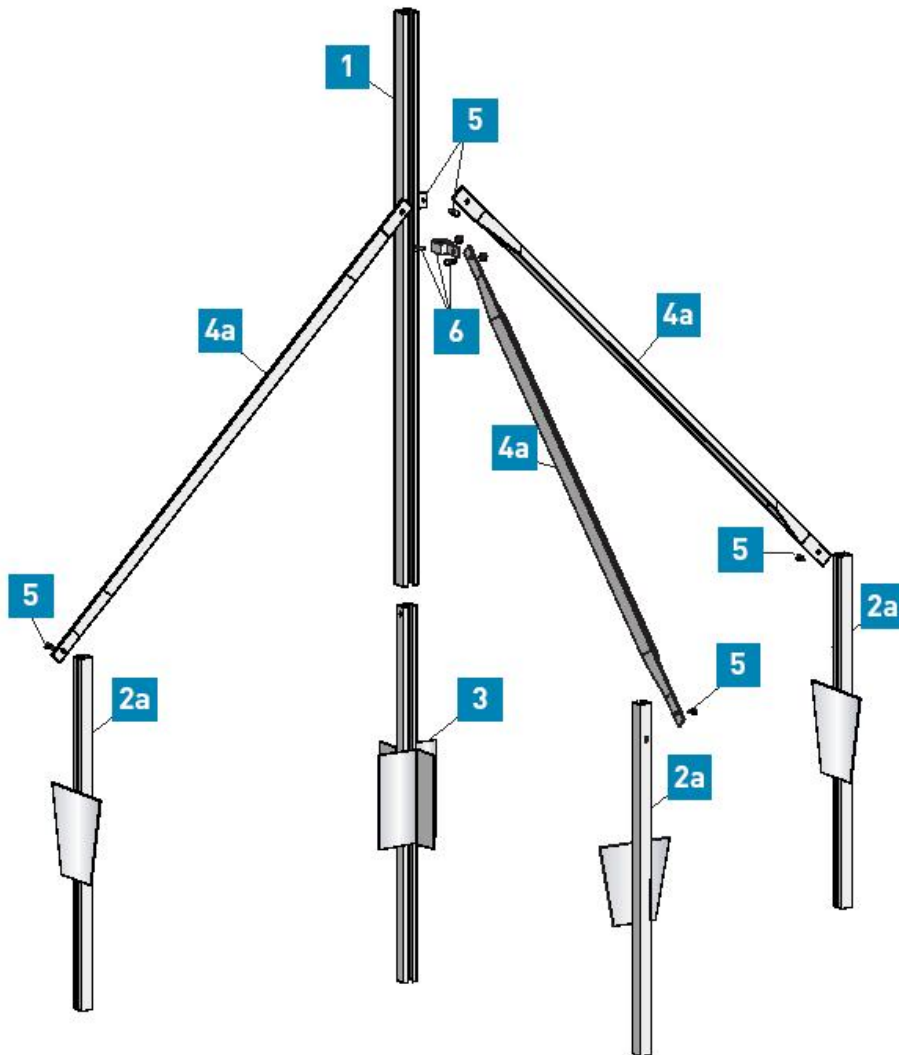

1	POST (pitch of 101.6)	5	HAMMERING PLATE + SCREW TH 10X30
2a	STRAIGHT ANCHOR POST	6	THIRD PROPS AND NUTS AND BOLTS
3	CORNER ANCHOR POST		
4a	PROP ON ANCHOR POST		



ACCESSORIES OF FIXING THE MESH TO THE GROUND,

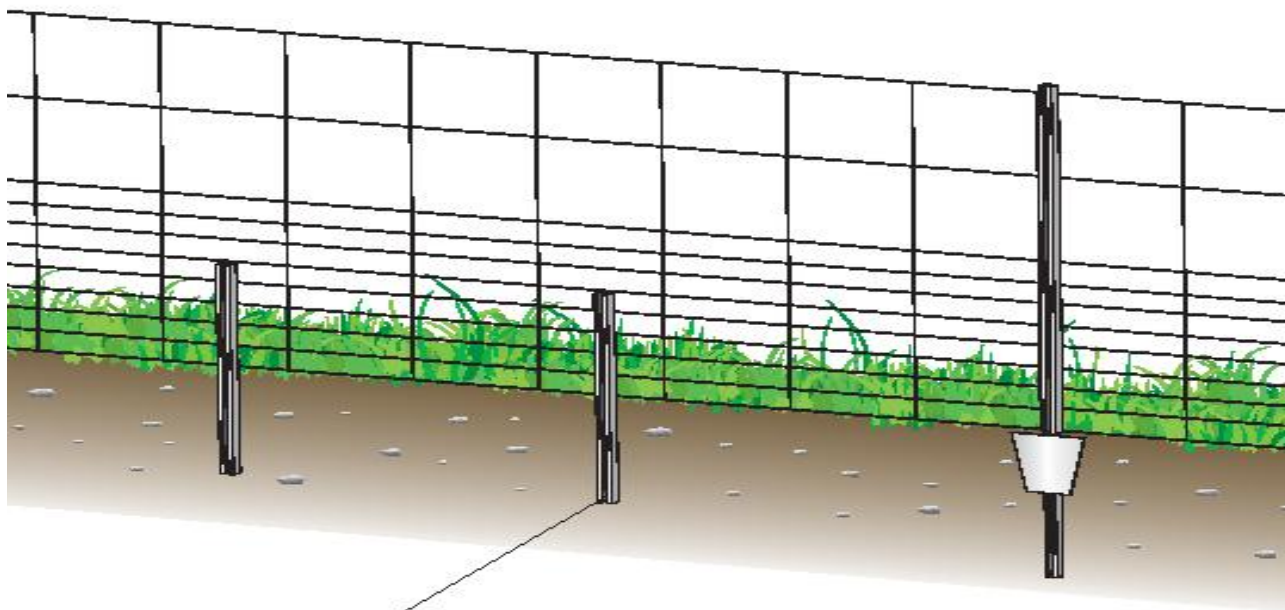

8



CAUTION
Take care to drive the hinges correctly (opening of the wire support towards the bottom)

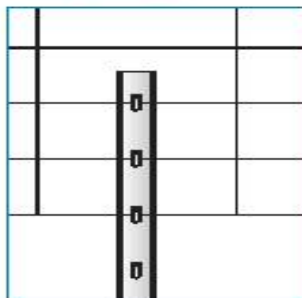



Premier wire netting

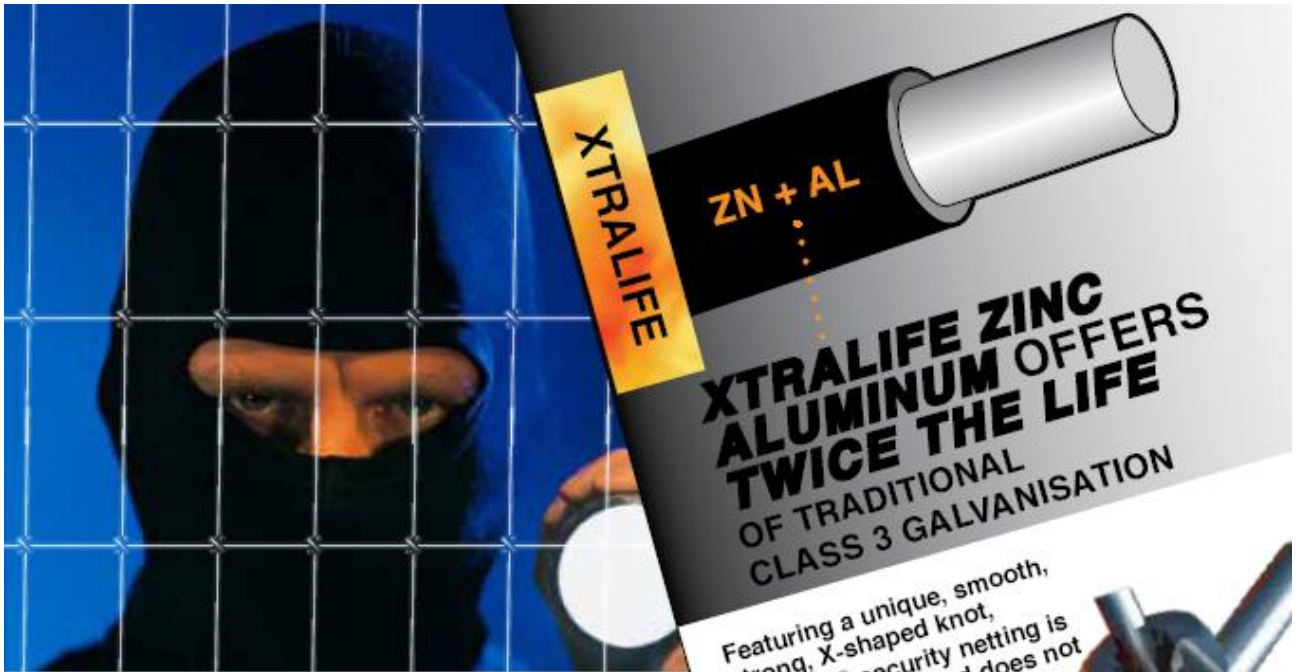

XTRALIFE

ZN + AL

XTRALIFE ZINC ALUMINUM OFFERS TWICE THE LIFE OF TRADITIONAL CLASS 3 GALVANISATION

Featuring a unique, smooth, strong, X-shaped knot, XFENCE® security netting is self-supporting and does not sag. It is therefore more durable than other netting type products and takes fencing technology to a whole new dimension.



SPECIFICATIONS SECURITY FENCE

High Tensile XFENCE® Security Netting is self supporting and requires no additional support wires or ring clips to secure saving you labour. Unlike chainlink with only one cut required to gain access, every line and stay wire must be cut to penetrate the XFENCE® security netting. The premium grade high tensile wire ensures that your security fence will not sag or disfigure over time.

All manufactured from premium grade high tensile wire



19 Line Wires	
High Tensile Line Wires (Horizontal)	2.5mm
High Tensile Stay Wires (Vertical)	2.5mm
Knot Wire	2.5mm
Stay Wire Spacings	50mm
Roll Length Available In	15 & 30M
Line Wire Spacings	100mm (4")



The XTRALIFE coating offers the ultimate solution for high quality and long life. XTRALIFE is the most advanced coating available, which offers BOTH barrier and galvanic protection from a single coating. The outer layer provides the galvanic protection and the inner layer provides the barrier protection. Result-twice the life!

STRONG · SECURE · SUPERIOR

STOP THIEF!





McVeigh Parker XFENCE Security System

Components		Length /Dia	Thickness	Weight	Retail
1	POST - Hook spacing 101.6mm	1.5m	2mm	3.80kg	9.50
		2.0m	2mm	5.25kg	13.32
2a	Straight anchor post	1.0m	3mm	4.15kg	12.20
		1.2m	3mm	4.70kg	13.51
2b	Anchor post for rocky ground	0.75m	3mm	2.75kg	12.90
2c	Anchor post for difficult ground	-	-	-	-
3	Corner anchor post	1.2m	3mm	5.85kg	18.65
4b	Strut for end/corner posts	2.0m	3mm	3.20kg	11.33
5	Plate & Bolt fixing 10 x 30			0.10kg	1.80
6	Barcket for Corner/ three way support			0.32kg	3.66
8	Ground centre fixing post 7 line	0.7m	2mm	0.75kg	3.40
10	Cranked extension	a=0.27m	2mm	2.1kg	6.75
		b=0.47m			
11	Vertical extension	0.7m	2mm	2.95kg	4.95
12	Manual socket plate			2.60kg	35.00
13	Pneumatic driver socket		28mm dia	5.00kg	292.66
	Extra over for powder coating - green	per mtr			
	XFENCE XHT12-110-7.5 Boundary 50m	1.1m	2.5mm	62kg	174.35
	XFENCE XHT18-180-5 Security 50m	1.8m	2.5mm	82.6kg	306.56

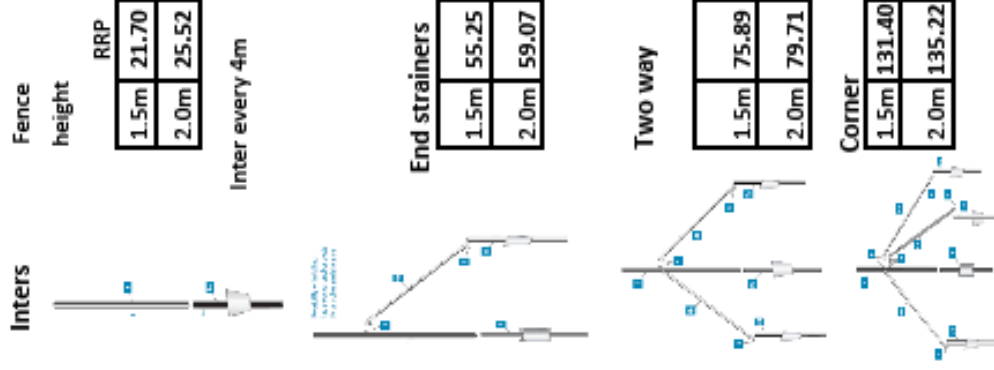



McVeigh Parker

'Pushing the boundaries'

Leading stockist & distributor

XFENCE® coupled with the unique steel post system which make **XFENCE SECURITY SYSTEMS** promises new dimensions in security & highway fencing that simply can't be overlooked.

Stronger and more resilient than chain link and welded mesh, easier to erect. It has the X-Factor written all over it and it will deliver major dividends for a wide ranging security and perimeter fencing needs.

With XFENCE wire netting you get

A wire netting that has a joint which has been proven to be 24% stronger than other market equivalent,

An alu/zinc coating which last three/four times longer than heavy galvanised.

A high tensile wire that not only retains its tension for its lifetime, it is also very difficult to penetrate.

A smooth non obtrusive wire netting that will be safe around people and will not impose on the landscape.

With XSS steel posts you save valuable time and money, the benefits are...

No drilling

No concreting

Less soil disturbance

Easy wire fixation

Speed in erection

Versatility, the system can be permanent, semi permanent or temporary.

**Tomorrow's Fencing
technology...today**

HEAD OFFICE: McVeigh Parker & Co Ltd, Southend Bradfield, Reading, Berkshire, RG7 6HA T: 0118 9744777

KENT BRANCH: Thornden farm, Lenham Rd, Headcorn, Ashford, Kent, TN27 9LH T: 01622 891095

SUSSEX BRANCH: Stane Street, Billingshurst, West Sussex, RH14 9JR T: 01403 784250

HERTS BRANCH: Little Hadham Rd, Much Hadham, Ware, Herts, SG10 6HL T: 01279 842842

WORCS BRANCH: Unit 16, Wilden Land Ind.Estate, Wilden Lane, Sourport-on-Severn, Worcs, DY13 9JY T: 01299 826111

LANCS BRANCH: Unit 3a, Link 25 Business Park, Wigan Road, Aston-in-Makefield,, Wigan, WN4 0DA T: 08451207755

Tel: 0845 1207755 www.mcveighparker.co.uk email: sales@mcveighparker.co.uk